



ALLEN CODING
A DIVISION OF ITW

Handheld

Universal control panel for thermal transfer printers 55sst, of NGT+ and of XL series

OPERATING INSTRUCTIONS

Important Notes

Operating instructions

Description	Version
Handheld	M00301101EN0713

The operating manual is a translation of the original operating instructions.

Applicability

The present operating instructions apply to devices with the following article number.

Device name

Article Number	Description
100458	Handheld

Using this manual

- First read the Chapter on “Safety Information” before you begin working with the device.
- The operating manual enables safe working on and with the device. It is essential that you comply with all safety instructions contained therein.
- Read the complete operating manual before installing and commissioning the device.
- The operating manual is a part of the device. It has to be stored so that every person that works on and with the device has access to it at all times. The manual must be complete and in an easily readable condition.
- When the device is passed on, you have to enclose the operating manual.
- If the operating manual is lost, please ask for a replacement. Information on the current version of the operating manual may be found on our website www.AllenCoding.com.
- The information provided in these Operating Instructions relate to the devices described under “Applicability”.
- For additional technical information on the device, please refer to the service manual.

Copyright

The present document and the described devices therein belong to the company Allen Coding GmbH. All rights remain reserved. Reproduction of this document, in full or in part, requires prior explicit and written approval of the company Allen Coding GmbH.

©Copyright 2013 Allen Coding GmbH, all rights reserved.

Disclaimer

The company Allen Coding GmbH undertakes all measures to ensure that the published document is up to date at the time of publication. However, no guarantee may be given that the document is error-free. The Allen Coding GmbH does not accept liability for possible damages that may have been caused by faulty information in this document. The company Allen Coding GmbH reserves the right to change the present document at any time without prior notice and to alter its content in regards to continuous product improvement.

Manufacturer

Allen Coding GmbH
Friedrich-Bergius-Ring 30
D-97076 Würzburg
Direct +49 931 250 76 - 0
Fax +49 931 250 76 – 50
Email: info@allencoding.com
Website: www.AllenCoding.com

Table of Contents

Important Notes..... 3

Table of Contents 4

1 Product Identification 6

1.1 Characteristic data6

1.2 Compliant Use.....6

1.2.1 Ambient conditions.....6

1.2.2 Designated use.....6

1.2.3 Qualification of personnel.....6

1.3 Technical data7

1.3.1 Mechanical data.....7

1.3.2 Electrical data.....7

1.4 Identification of the device7

1.5 Compliance Information7

1.5.1 CE-compliance.....7

1.5.2 EMC Compliance Statements.....8

1.5.3 RoHS / WEEE – compliance.....8

2 Product Specifications..... 9

2.1 Safety Requirements.....9

2.2 Deliverable Items9

2.3 Description of device10

2.3.1 Handheld Interfaces.....10

3 Safety Information..... 12

3.1 Configuration of the safety instructions12

3.2 Used pictograms13

3.3 Hazards during compliant use.....13

4 Installation 14

4.1 Unpacking14

4.2 Connecting the handheld.....14

4.2.1 Connection to printer of XL series:15

4.2.2 Connection to printer NGT2+ / NGT4+ of NG-Series15

4.2.3 Connection to printer 55sst15

5 Startup 16

6 Operating 17

7 Troubleshooting 18

8	Cleaning and Maintenance.....	19
8.1	Cleaning.....	19
8.2	Maintenance	19
9	Maintenance	20
9.1	Spare parts	20
9.2	Service address	20
10	Transport and storage.....	21
10.1	Transport.....	21
10.2	Storage	21
11	Disposal.....	22
	Appendix.....	23
	EC-Compliance Statement.....	23
	Spare parts	24

1 Product Identification

1.1 Characteristic data

Handheld	
Article Number	100458
WEEE-Reg.-Nr. DE	84410135
Unique Identification	MAC address on type plate

1.2 Compliant Use

1.2.1 Ambient conditions

Handheld		
Ambient temperature operation	[°C]	0- 35
Relative humidity operation (non-condensing)	[%]	10- 70
Protection class		IP 30
Ambient temperature transport and storage (for a maximum of 10 days)	[°C]	-30- 80
Relative humidity transport and storage (non-condensing; for a maximum of 10 days)	[%]	10- 90

1.2.2 Designated use

The handheld is designed to be used only in combination with the following thermal transfer systems:

- Thermal transfer printer NGT2+ / NGT4+ of NGT-Series
- Thermal transfer printer of XL series
- Thermal transfer printer 55sst

1.2.3 Qualification of personnel

Operation and set-up:

Operation and set-up of the device may only be performed by sufficiently qualified and trained personnel that have been authorized by operator to perform these tasks.

Installation, cleaning and maintenance:

Installation, cleaning and maintenance of the device may only be performed by fully qualified and trained technical personnel.

Maintenance:

Maintenance of the device may only be performed by the manufacturer’s technical personnel or by fully trained and qualified technical personnel.

1.3 Technical data

This Section contains information on the mechanical and electrical properties of the Printing System and its accessories.

1.3.1 Mechanical data

Handheld		
Equipment height	[mm]	40
Equipment width	[mm]	240
Equipment depth	[mm]	135
Weight	[kg]	0,7

1.3.2 Electrical data

Handheld		
Rated voltage	[V _{DC}]	5
Power consumption	[A]	2

1.4 Identification of the device

Type plate

The nameplate attached to the device contains the following data:



- | | |
|---|-------------------|
| ① Manufacturer | ④ CE identifier |
| ② Device type with article number | ⑤ WEEE identifier |
| ③ MAC address for unique identification | |

1.5 Compliance Information

1.5.1 CE-compliance



NOTE

CE-conformity

The product's CE conformance is certified by attachment of the CE symbol to the name plate. A sample of the declaration is found in the Appendix to these Operating Instructions; see "**EC-Compliance Statement**".

The device meets the requirements of the following European EC-Guidelines:

- EMC guideline **2004/108/EG**

1.5.2 EMC Compliance Statements

European Union (EU) Electromagnetic Compatibility Directive Compliance Statement

This product is in conformity with the protection requirements of EU Council Directive 2004/108/EC on the approximation of the laws of the Member States relating to electromagnetic compatibility.

This product has been tested and found to comply with the limits for Class A Information Technology Equipment according to the European Standard EN 55022.

Warning: This is an EN 55022 Class A product. In a domestic environment this product may cause radio interference in which case the user may be required to take adequate measures.

Federal Communications Commission (FCC) Emissions Compliance Statement

This equipment has been tested and complies with the limits for a Class A digital device, pursuant to Part 15 of the FCC Rules. These limits are designed to provide reasonable protection against harmful interference when the equipment is operated in a commercial environment.

This device complies with Part 15 of the FCC Rules. Operation is subject to the following two conditions: (1) this device might not cause harmful interference, and (2) this device must accept any interference received, including interference that might cause undesired operation.

Warning: Operation of this equipment in a residential area is likely to cause harmful interference, in which case the user will be required to correct the interference at their own expense.

Industry Canada Class A Emissions Compliance Statement

This Class A digital apparatus complies with Canadian ICES-003.

1.5.3 RoHS / WEEE – compliance

RoHS

The product complies with the relevant provisions of the RoHS Directive for the European Union.

WEEE Directive Statement for the European Union

WEEE-Reg.-Nr. DE	84410135
------------------	----------

In common with all Electronic and Electrical products the product should not be disposed of in household waste. Alternative arrangements may apply in other jurisdictions.

2 Product Specifications

In this Chapter you will find information on the deliverable items and on the furnishings of the device.

2.1 Safety Requirements



NOTE

Please always follow the safety instructions.
See Chapter “*Safety Information*”.

2.2 Deliverable Items



NOTE

Check the deliverable items for completeness and condition.

After receipt of the shipment, please check immediately to see whether all items listed on the delivery ticket are included and are undamaged. The manufacturer does not accept liability for deficiencies that have been claimed subsequently. Complain against:

- Transport damages directly to the shipping service.
- Deficiencies and/or incompleteness immediately to the manufacturer or your distributor.

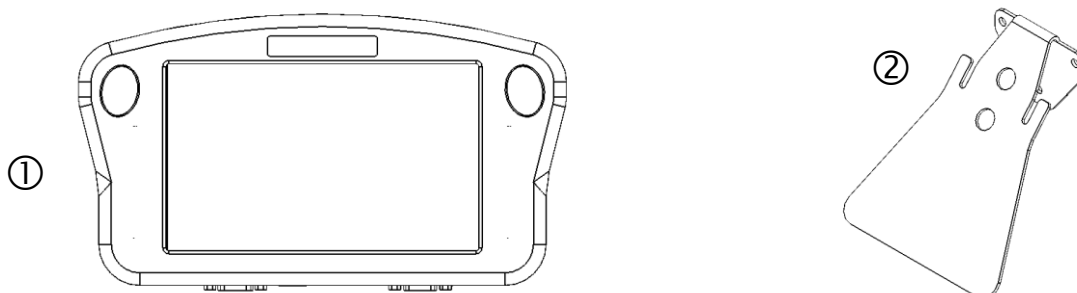

The following components belong to the standard deliverable items for the device

Position	Count	Article number	Specification
1	1	100458	Handheld
2	1	100752	Mounting for handheld
3	1	-----	CD with operating instructions

The following components belong to the optional deliverable items for the device

Position	Count	Article number	Specification
4	1	100750	Connecting cable for connection between handheld and printers of XL series
5	1	100751	Connecting cable for connection between handheld and printer 55sst
6	1	102080	Connecting cable for connection between handheld and printer NGT2+ / NGT4+ of NGT-Series
7	1	100753	Ethernet cable for connection between handheld and printers of NGT-Series

2.3 Description of device

2.3.1 Handheld Interfaces

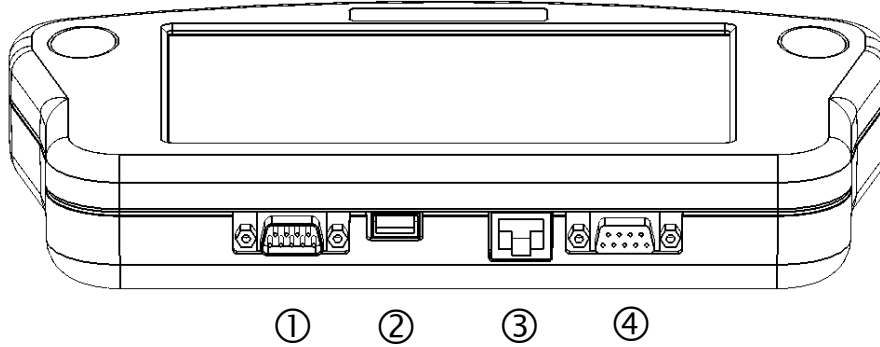

1. Communication Interface RS 232 (D-Sub 9-pin connector) COM1

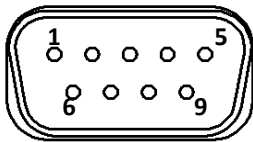

Pin	Description/Function
1	NC
2	RxD – received data
3	TxD – transmit data
4	NC
5	GND – signal ground
6	NC
7	NC
8	NC
9	NC

2. USB connection (port Type A)

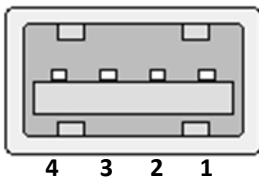

Pin	Description/Function
1	+ 5V
2	data -
3	data +
4	GND

3. Network connection (female connector RJ45)

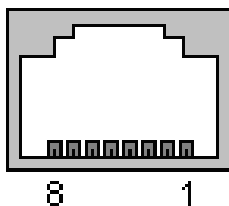

Pin	Description/Function
1	D1+
2	D1-
3	D2+
4	D3+
5	D3-
6	D2-
7	D4+
8	D4-

4. Communication interface / System interface (D-Sub 9-pin female connector) COM0

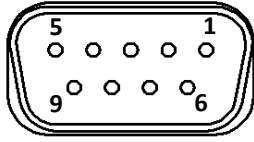

Pin	Description/Function
1	VCC + 5 V
2	TxD – transmit data
3	RxD – received data
4	GND – ground external
5	GND – ground external
6	GND – ground external
7	VCC + 5 V
8	VCC + 5 V
9	VCC + 5 V

3 Safety Information

This Chapter contains information on the configuration and relevance of the safety information presented in these operating instructions, and also information on possible hazards which may occur even for compliant usage of the device.

3.1 Configuration of the safety instructions

 **SIGNAL WORD**







Type and source of hazard

Explanation of the hazard and information on possible consequences of non-compliance



- Activities/prohibited actions to help prevent accidents.

	The pictogram denotes the type of hazard	
	The safety sign  before the signal word indicates a possibility of personal injury	
	The signal word denotes the severity of the hazard	
	SIGNAL WORD	Consequences when hazard occurs
	HAZARD	Severe physical injury or death (irreversible)
	WARNING	Severe physical injury or death (irreversible)
	CAUTION	Slight/minor physical injury (reversible)
	ATTENTION	Property damage to machinery and/or to nearby assets
	The reference text describes: <ul style="list-style-type: none"> ▪ type and source of hazard, ▪ the possible consequences of disregarding the safety instruction, ▪ measures or restraints to prevent the hazard. 	

3.2 Used pictograms

Pictogram	Meaning
	Warning of a general hazard
	Warning of possible property damages
	Before performance, observe the corresponding information in the operating manual
	General note

3.3 Hazards during compliant use

-  **CAUTION**
-  **Potential hazard caused by incorrect accessories and spare parts!**
- The use of accessories and spare parts that are not recommended by the manufacturer may compromise safety, functionality and efficiency of the device. Any liability and warranty for any damages caused by not recommended accessories and spare parts or non-intended use is excluded by the manufacturer.
- Thus use manufacturer recommended accessories and spare parts exclusively.
-

4 Installation

In the following Chapter you will find information on installation of the device.

 **CAUTION**



Potential hazard due to incorrect or non-compliant installation!

Incorrect or improper assembly of the device may impair safety, functionality and efficiency of the device.

- The installation of the device may be performed exclusively by qualified technical expert personnel.
- Follow the relevant instructions in the operating manual.

4.1 Unpacking

 **CAUTION**



Hazards due to defects or transport damage!

Transport damage to the device may result in unforeseeable hazards to personnel and/or property.

- On unpacking the device, check for any visible damage.
- Never ever connect a damaged device to the voltage supply or a printing system.
- Broken glass or plastic can cause injuries to hands. Liquids may emerge from a broken display. Avoid contact with this liquid. Clean carefully any body parts or clothing that have been exposed to these liquids.
- In case of transport damage, consult the manufacturer or your distributor.



NOTE

Check the deliverable items for completeness and condition.

After receipt of the shipment, please check immediately to see whether all items listed on the delivery ticket are included and are undamaged. The manufacturer does not accept liability for deficiencies that have been claimed subsequently. File complaints with:

- Transport damages directly to the shipping service.
- Deficiencies and/or incompleteness immediately to the manufacturer or your distributor.



NOTE

Recycling of transport packing

The transport packaging may be stored for later recycling, e.g. transport or storage.

Step 1: Open the transport packing.

Step 2: Check whether all items listed on the delivery ticket are included and undamaged.

Step 3: Remove all components of the device carefully from the transport packing.

4.2 Connecting the handheld

Connect the 9-pin connector of the connection cable in use firmly to the system interface of the handheld (female connector on the bottom right of the handheld). Tighten the screws.

Turn off the printing system that is to be connected with the handheld.

Connect the free end of the connecting cable to the female connector of the printing system. Ensure that the connection cable is plugged in firmly.

Before switching on the printing system, read the information in the chapter "Startup"

The printing systems are fitted with the following connectivity options:

4.2.1 Connection to printer of XL series:

Use the 15-pin female connector to connect the handheld with a printer of the XL series

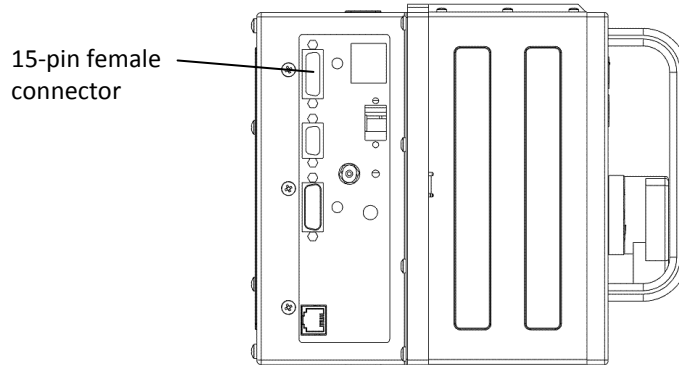

4.2.2 Connection to printer NGT2+ / NGT4+ of NG-Series

Use the 3-pin and the 9-pin female connectors to connect the handheld to the printer NGT2+ / NGT4+ of the NG-Series. Additionally, the handheld may be connected to the printer via the enclosed Ethernet cable.

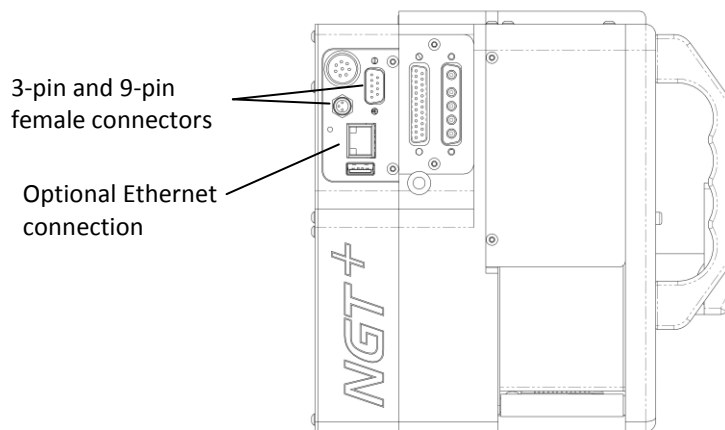

4.2.3 Connection to printer 55sst

Use the 4-pin female connector to connect the handheld to the control module of the printer.

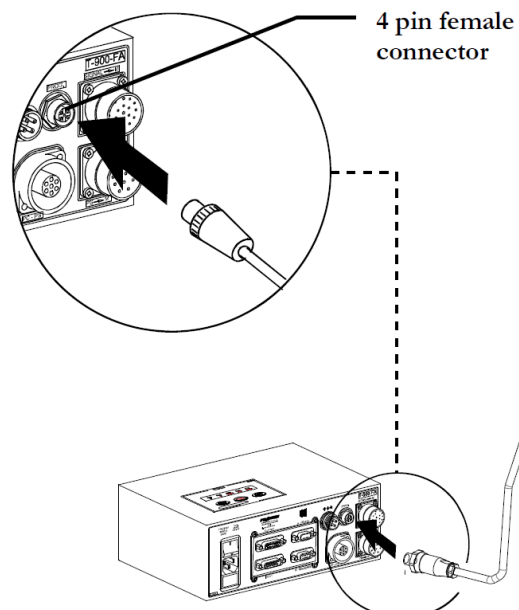

5 Startup

ATTENTION



Damage to device due to condensate and overheating

Exposing the device to excessive heat or cold while transport or storage, may cause damage to the device.

- Prior to startup, store the device for 24 hours within conditions corresponding to the later ambient conditions in respect to temperature and humidity. This ensures that the device can acclimatise.

Turn on the printing system that the handheld has been connected to. The handheld will start automatically and will boot until the following screen is displayed:

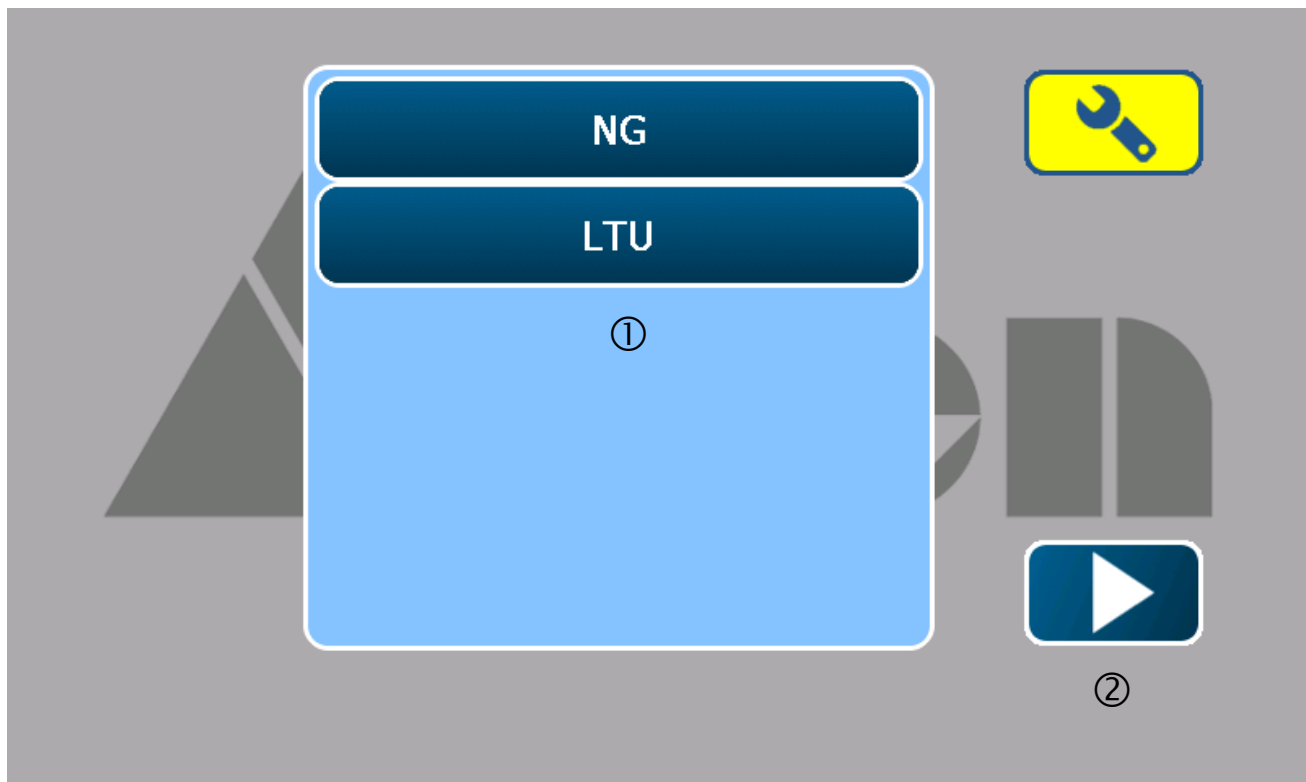

- ① Selection of programs installed on handheld. This screen can vary depending on the installed programs.
- ② Start button

Select the printing system that the handheld is connected to and confirm the selection by touching the start button (2). In the future, the handheld will automatically start with these settings. To change these settings, the device has to be reset to delivery status. This can be done within each program.

6 Operating

 **CAUTION**



Do not place handheld on sloping surfaces.

By falling, the device may take damage or injure persons.

- Use the recommended mounting to store the device.
-
-

ATTENTION



Damage to handheld due to falling and shaking

Bending and deforming may cause damage to the handheld or to components. Do not let the handheld fall or expose it to excessive shaking.

- Store the handheld in the designated mounting and install the mounting in a vibration-free place.
-
-

ATTENTION



Keep handheld dry

Moisture and liquids of all sorts may cause damage to components or electrical circuits of the device.

- Do not switch on the device, if wet.
 - If the device is already switched on, turn it off immediately.
 - Dry the device and consult the manufacturer or distributor for repair or maintenance.
-
-

The handheld is equipped with a touch screen. Operate the device by touching the screen with a fingertip or a specific polyacetal pen. Do not use any other means to operate the device.

After configuring the handheld on start up once, it will start the selected program automatically. The operation of the programs is described in the respective operation manuals.

7 Troubleshooting

Error messages are specific for each printing system. Please refer to the help section or the operation manual of the respective program.

8 Cleaning and Maintenance

CAUTION



Hazards during cleaning and maintenance activities!

Switch off the device during cleaning and maintenance work, otherwise personnel safety may be at risk and damage to the device or other nearby property may result.

- Always deactivate the power supply to the device during cleaning and maintenance activities. Pull the mains plug.
 - During maintenance and during your absence, secure the device so that no changes may be performed by other persons or situations.
 - Maintenance and cleaning work may only be performed by trained personnel.
-

8.1 Cleaning

ATTENTION



Damage to the device due to improper cleaning

Use of improper cleaning methods and the use of incorrect cleaning agents may result in damage to electronic and mechanical components of the device.

- Disconnect the device from the power supply before you begin cleaning.
 - Follow the cleaning instructions described in the operating manual.
 - Use only cleaning agents specified by the manufacturer.
-

Clean the handheld with a soft clean cloth, if necessary. Permissible cleaning agents are water and isopropyl alcohol. Avoid moisture or liquid to intrude into the device and swipe drops from the device immediately.

8.2 Maintenance

ATTENTION



Damage due to improper maintenance – do not disassemble, modify or repair the device.

Changes to or modifications of the device may lead to the expiration of the manufacturer's warranty.

- For repair or maintenance, please consult the manufacturer or distributor.
-

9 Maintenance

9.1 Spare parts

Refer to the Spare Parts List under “*Spare parts*” in the appendix.

9.2 Service address



Germany

Allen Coding GmbH
Service Department
Friedrich-Bergius-Ring 30
D-97076 Würzburg
Tel.: +49 931 250 76 - 911
Fax +49 931 250 76 – 50
Email: support@allen.de

United Kingdom

Allen Coding Systems
Unit 9, Gateway 1000,
Whittle Way, Arlington Business Park,
Stevenage, Herfordshire SG1 2FP
Tel.: +44 1438 347 770
Fax +44 1438 347 771
Email: info@allencoding.co.uk

Spain

Allen Coding Systems
Carretera del Mig, 83-87
08940 Cornellà de Llobregat,
Barcelona
Tel.: +34 93 470 56 00
Fax +34 93 473 56 21
Email: informacion@allencoding.com

Website: www.AllenCoding.com



NOTE

Important information in case of defects

In case of defects in equipment, please provide the following information:

- Serial number/MAC-Address
- Equipment type
- Description of fault
- Software- / Firmware-version
- Any affected components/assemblies

10 Transport and storage

10.1 Transport

Transport the device only in the packaging in which you received it.

10.2 Storage

Store the device only under the stated, permissible ambient conditions regarding temperature and humidity. Relevant information is found in this operating manual under “***Ambient conditions***”. Protect the device against dust and dirt.

11 Disposal

The device consists of various materials which can be recycled and which have to be disposed of separately.

In the event of disposal of the device, follow the relevant legal guidelines. Since the disposal guidelines may differ from country to country, please consult with your supplier as necessary.

Notes to disposal:

- Material types should be disposed of separately. The objective should always be an environmentally compatible disposal which ensures maximum recycling of materials.
- Observe the material and disposal instructions that may be present on certain individual parts.
- Make use of the opportunity to return materials to the manufacturer or supplier.

Appendix

EC-Compliance Statement

EC-Declaration of Conformity
Handheld



EC-Declaration of Conformity
according to EC EMC directive 2004/108/EC, Annex IV 2
(Translation of the EC Declaration of Conformity)

Hereby we declare that the equipment named in the following adheres to the protection requirements of the EC guideline 2004/108/EC in regards to its concept, design and version that is marketed by us. Changes that have not been coordinated with us will invalidate this declaration.

Manufacturer

Allen Coding GmbH Friedrich-Bergius-Ring 30 D-97076 Würzburg	Direct: +49 931 250 76-0 Fax: +49 931 250 76-50 E-Mail: info@allencoding.com Website: www.AllenCoding.com
--	---

Equipment description



Function:	Operation terminal for Printing-Systems
Type/Model:	Handheld-100458
Year of construction:	2013

The conformity of the named equipment with the rules of the EC guidelines named above is proved by conformity with the following standards:

Applied harmonized standards: EN55022:2010; EN61000-6-2:2005	Additional applied standards: EN61000-4-2:2009 EN61000-4-3:2006 + A1:2008 + A2:2010 EN61000-4-4:2004 + A1:2010 EN61000-4-5:2006 EN61000-4-6:2009 EN61000-4-8:2010 EN61000-4-11:2004 FCC, Part 15, Class A, verification ICES – 003, Issue 4, February 2004
---	--

Details of signatory person

Dr. Stefan Balling	R&D Manager	Karin Putz	QM-Representative
(Name of signer)	(Position)	(Name of signer)	(Position)

 _____ Signature	 _____ Signature
---	--

Würzburg, 08.07.2013 (Place, Date)	Würzburg, 08.07.2013 (Place, Date)
---------------------------------------	---------------------------------------

Allen Coding GmbH Friedrich-Bergius-Ring 30 D-97076 Würzburg	Tel. +49 931 250 76-0 Fax +49 931 250 76-50	info@allencoding.com www.AllenCoding.com	Page 1 / 1 Version: V1.10 Stand: 08.Jul 2013
--	--	--	--

Spare parts

No.	Article number	Description	Count
1	100458	Handheld	1
2	100750	Connecting cable for connection between handheld and printers of XL series	1
3	100751	Connecting cable for connection between handheld and printer 55sst	1
4	102080	Connecting cable for connection between handheld and printer NGT2+ / NGT4+ of NG-Series	1
5	100753	Ethernet cable for connection between handheld and printers of NG series	1
6	100752	Mounting for the handheld	1